



# DLS-2XX series

## User Manual

*DAI 2 PIR motion sensor*



The DLS-2XX series is a DALI-2 compliant input device using PIR motion and daylight sensing technology. It is powered by the DALI bus. It uses passive infrared (PIR) technology to detect motion from people or pets within the monitoring area in real time. The product includes a built-in daylight sensor to measure ambient light levels in real time. By combining PIR detection with daylight sensing, it provides fast and accurate input for applications such as smart homes, hotels, offices, warehouses, and parking lots. The product adopts a ceiling-mounted installation method and is available in low-height and high-height installation type to accommodate different detection ranges.

This series of sensors can be paired with MEAN WELL's DLC-02 master controller, LED drivers, and DTP series touch panels to form a DALI-2 digital lighting system. It enables control of DALI luminaires, including on/off switching, dimming, and scene regulation, meeting daily lighting control requirements.

# Contents

1. Safety Guidelines	1
2. Introduction	1
2.1 Model Encoding	1
2.2 Features	1
2.3 Specification	2
2.4 Mechanical Specification	3
2.4.1 Low-mounting type	3
2.4.2 High-mounting type	3
2.5 Function Description	4
2.5.1 DALI Interface and Function Diagram	4
2.5.2 Detection radiation	4
2.5.3 Detection Signal	5
3. Installation	6
3.1 Installation Steps for Low-mounting type Flush Mounting	6
3.2 Installation Steps for High-mounting type Flush Mounting	6
3.3 Installation steps for High-mounting type Surface Mounting	7
4. Wiring Diagram	9
4.1 Sensor Power Supply Scheme	9
4.2 DALI-2 Digital Lighting System Commissioning	10
5. Application examples	11
5.1 PIR Motion Sensor/Group Example	11
5.2 Light and PIR Motion Sensors Interaction/Group Example	19
6. Common Faults and Troubleshooting	29
7. Warranty	30
8. Environmental declaration information	30

# 1.Safety Guidelines

- This product must be installed by a licensed electrician. Disconnect power before installation and wiring.
- The optimal installation height is 3m(DLS-203-P) or 8m(DLS-208-P), Do not install outdoors, as environmental temperature changes may cause false triggering. Avoid installing in locations with frequent temperature or airflow changes, as this may cause false triggering or detection failures.
- There should be no reflective objects directly in front of the sensor, as reflected light can cause the sensor to trigger incorrectly.
- Keep the sensor at least 2 meters away from strong electromagnetic sources such as Wi-Fi routers, security cameras, or microwave ovens to prevent interference.
- Due to the Fresnel lens design, tangential movement can be detected at a greater distance than radial movement.
- When ambient temperature approaches human body temperature range(36°~37°C/96.8~98.6°F), motion detection sensitivity may be reduced or non-responsive.

## 2.Introduction

### 2.1 Model Encoding

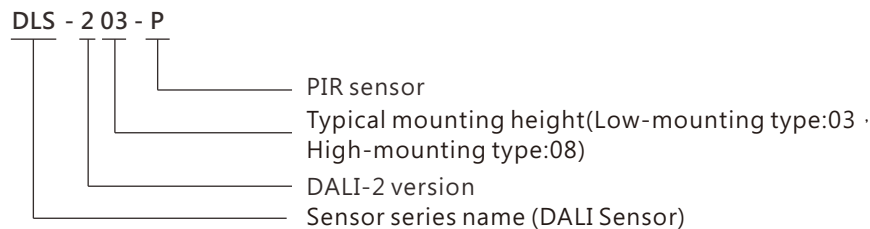

### 2.2 Features

- DALI-2 certified PIR motion sensor
- Compliant with IEC-62386-101/103/303/304 standards
- Compatible with DALI-2 controllers,such as MEAN WELL DLC-02
- Powered directly from DALI Bus
- PIR sensing technology
- Built-in daylight sensor

## 2.3 Specification

SPECIFICATION	DLS-203-P	DLS-208-P
Type	Low-mounting type	High-mounting type
<b>INPUT</b>		
INPUT VOLTAGE	9.5V~22.5V DC(powered by DALI BUS)	
CURRENT CONSUMPTION	Typ. current < 10mA@16VDC, Inrush current(Max.)<20mA	
START-UP TIME	10s self-test is initiated upon first power-up, with external motion detection disabled during this period	
PROTOCOL	DALI-2	
<b>FUNCTION</b>		
DALI STANDARD	Compliant with DALI standard IEC62386-101, 103, 303, 304	
FUNCTION	PIR motion detection+ daylight sensor	
HOLD TIME	5s(sensor hold time)+DALI master setting hold time	
DAYLIGHT SENSOR MEASUREMENT	2-65000Lux	
RADIUS DETECTION RANGE (BASED ON 100% SENSITIVITY)	Radius 3-4m @25°C, based on 3m mounting height and tangential motiondetection	Radius 5-6m @25°C, based on 10m mounting height and tangential motiondetection
<b>ENVIRONMENT</b>		
OPERATING TEMP. Note1	-25 ~ +50°C	
OPERATING HUMIDITY	10 ~ 85% RH	
STORAGE TEMPERATURE & HUMIDITY	-40 ~ +80°C · ≤85% RH	
IP RATING	IP20	Flush mounting: IP20, Surface mounting : IP54
<b>SAFETY &amp; EMC</b>		
SAFETY STANDARD	EN60669-1 ; EN IEC60669-2-1	
EMC EMISSION	EN IEC55015	
EMC IMMUNITY	EN IEC61547	
<b>OTHERS</b>		
FACTORY DEFAULTS	Delay settings:5S,Indicator light: ON	
WIRE SIZE	0.5~1.5 mm <sup>2</sup> (AWG 20~16)	
MOUNTING HEIGHT	2-6m,typical : 3m	2.5-10m, typical : 8m
DRILL HOLE	ø55-65mm	ø55mm
SIZE/UNIT(L*W*H)	ø89 * 34mm	105 * 105 * 80.8mm(ceiling flush mounting), 105 * 105 * 65.8mm(ceiling surface mounting)
PACKING	0.1Kg;40pcs/4.1Kg/1.18CUFT	0.25Kg;20pcs/5.0Kg/1.10CUFT
<b>NOTE</b>		
1. The detection range may increase as temperature decreases and decrease as temperature rises		

## 2.4 Mechanical Specification

Unit: mm Tolerance : ±1

### 2.4.1 Low-mounting type---order number : DLS-203-P

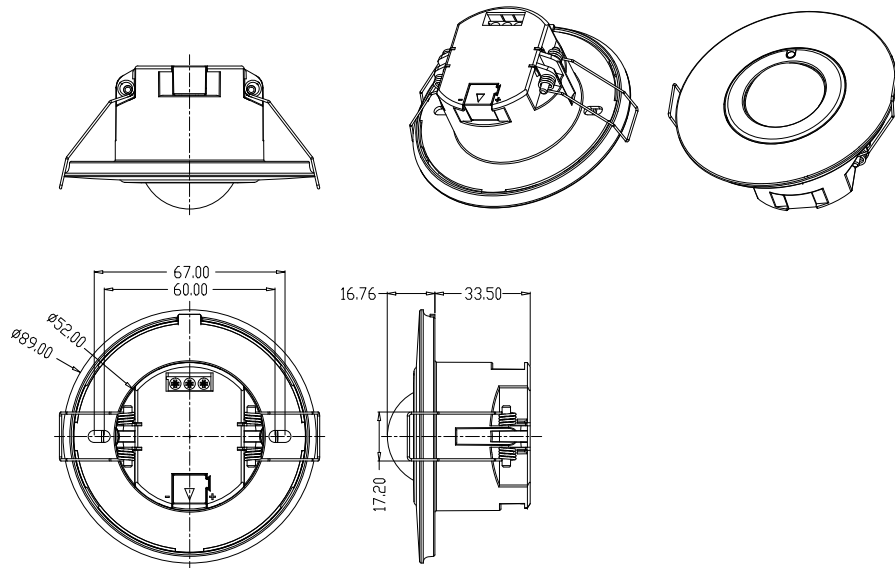

### 2.4.2 High-mounting type---order number : DLS-208-P

#### 2.4.2.1 Surface mounting

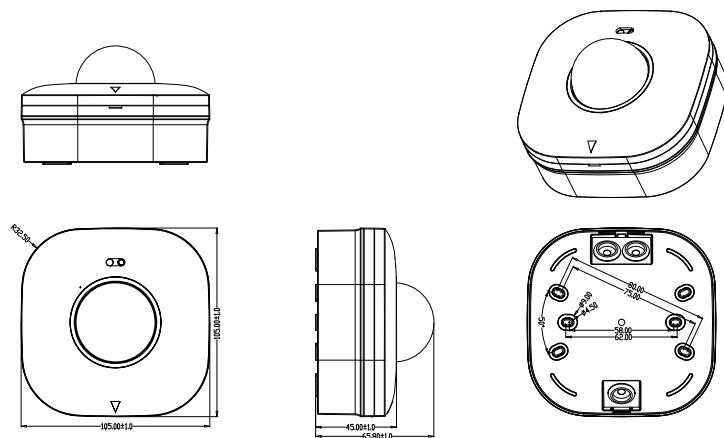

### 2.4.2.2 Flush mounting

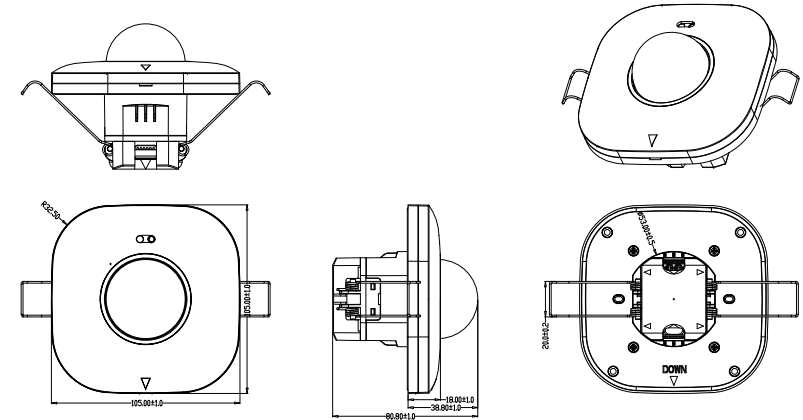

## 2.5 Function

### 2.5.1 DALI Interface and Function Diagram

#### Low-mounting type:DLS-203-P

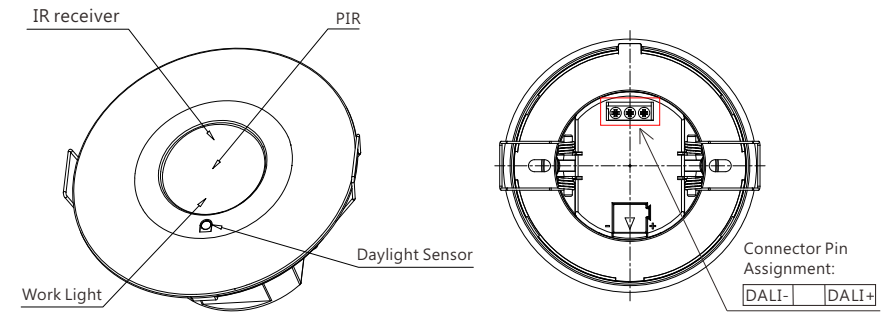

#### High-mounting type:DLS-208-P

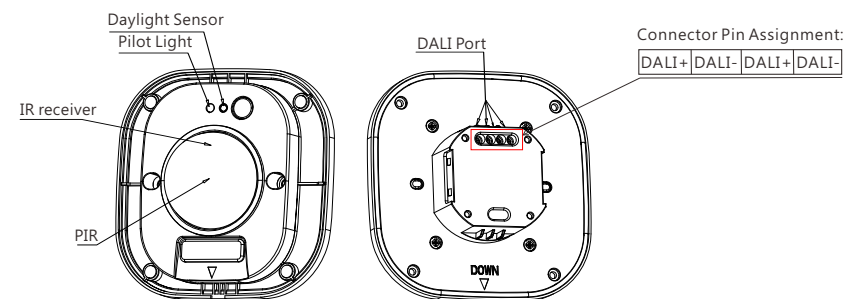

## 2.5.2 Detection radiation

PIR sensor is highly recommended ceiling flush mounting and its detection radiation is as below shows :

Low-mounting:DLS-203-P

Detection radiation top view(unit:meter)

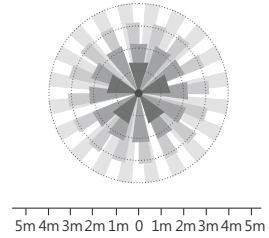

Detection radiation side view(unit:meter)

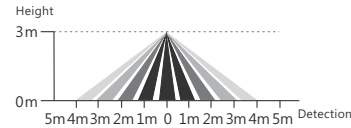

High-mounting type: DLS-208-P

Detection radiation top view(unit:meter)

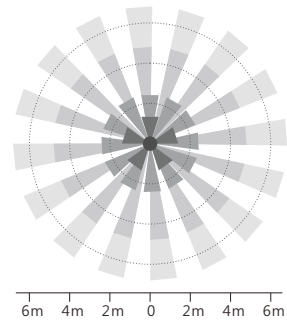

Detection radiation side view(unit:meter)

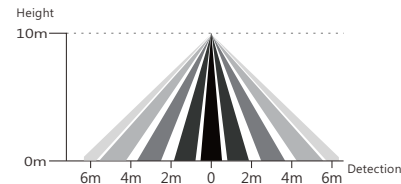

## 2.5.3 Detection Signal

The product detects human movement signals to determine the presence or absence of movement (occupied/unoccupied) in non-sleep states. The following is an explanation of the movement signals:

Moving signal: detect the human significant moving (walking) in the detection area

## 3.Installation

### 3.1 Installation Steps for Low-mounting type Flush Mounting

- (1)Recommended ceiling opening size:  $\Phi 55-65\text{mm}$ .
- (2)Connect the DALI wire to the terminal block properly, then bend the spring clip backward and push it into the pre-drilled hole in the ceiling.
- (3)Ensure the device is stable and reliable after installation.

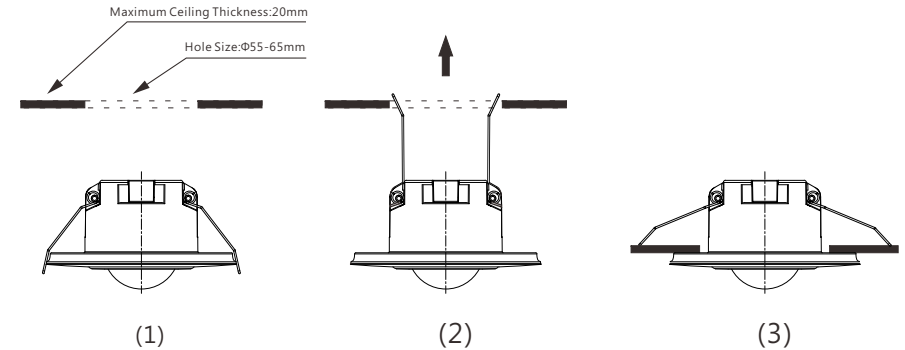

### 3.2 Installation Steps for High-mounting type Flush Mounting

- (1)Combine the base accessories with the PIR Sensor.
- (2)Recommended ceiling opening size:  $\Phi 55\text{mm}$ .
- (3)Connect the DALI wire to the terminal block properly, then bend the spring clip backward and push it into the pre-drilled hole in the ceiling.
- (4)Ensure the device is stable and reliable after installation.

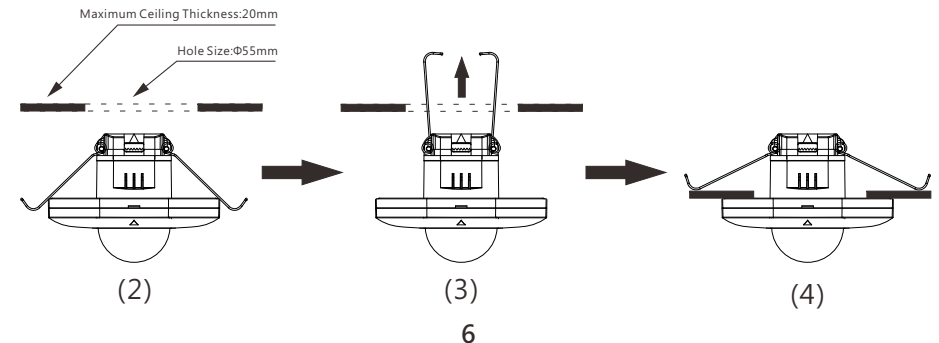

### 3.3 Installation steps for High-mounting type Surface Mounting

3.3.1 Use a screwdriver to open the pre-reserved screw holes on the surface-mounted base, and use diagonal pliers to cut an outlet as needed.

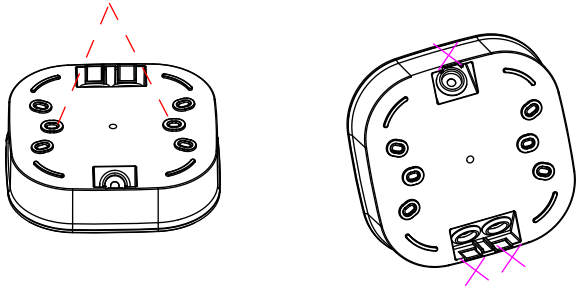

3.3.2 Drill holes in the ceiling as per the screw hole spacing on the bottom cover, then install the M6x28mm plastic expansion tubes.

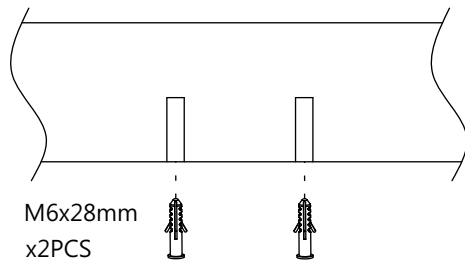

3.3.3 Use M3.5x26mm self-tapping screws to fasten the bottom cover to the ceiling.

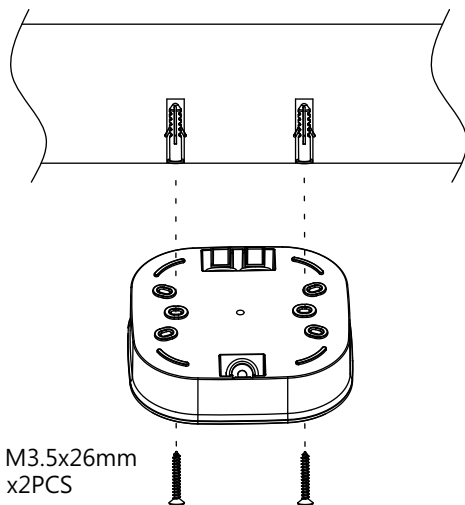

3.3.4 Pass the DALI wire through the bottom cover, fasten it to the sensor's DALI terminal, and then secure the sensor with four M3x8mm screws.

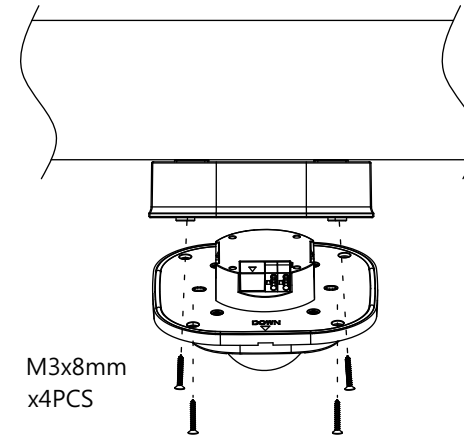

3.3.5 Snap the face cover on in the direction of the arrow to finish the installation.

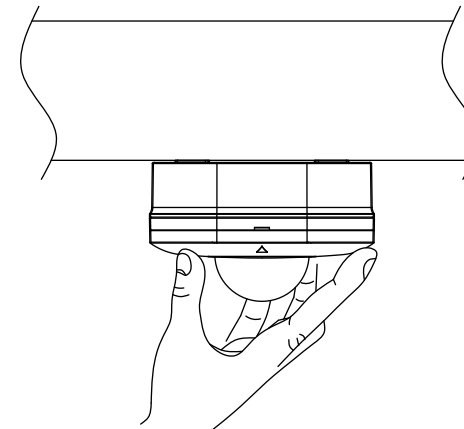

## 4. Wiring Diagram

### 4.1 Sensor Power Supply Scheme

Simply wire the sensor to the polarity-free DALI bus for installation and operation.

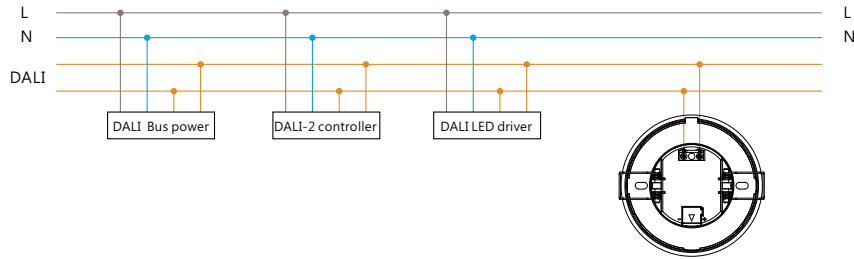

Note: If the controller has a built-in DALI bus power supply, it is not necessary to add an additional independent DALI bus power supply.

### 4.2 DALI-2 Digital Lighting System Commissioning: (MEAN WELL DLC-02 building in DALI Bus)

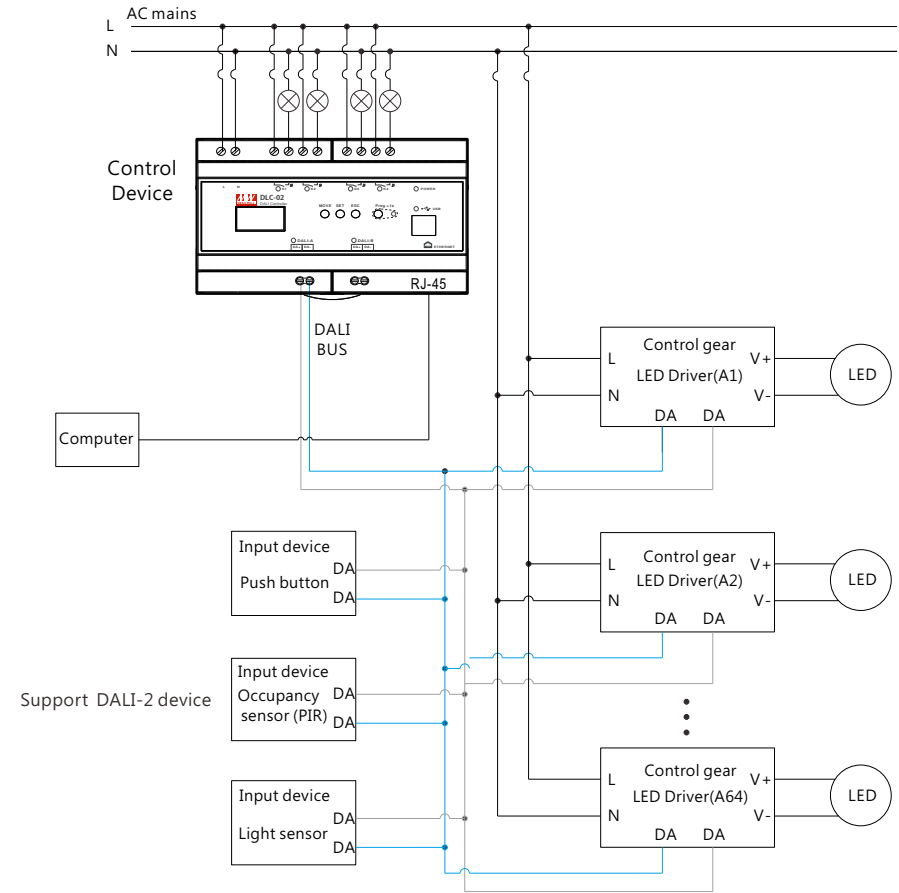

MEAN WELL DLC-02 controller, each channel can be connected up to 12 input devices but the maximum number of input devices that can be connected is determined by the connected DALI bus power and operating current of the input device. For example, when 64(Lamp) LED drivers (2mA) are connected, the maximum remaining applicable current on the DALI bus is  $250\text{mA} - (2\text{mA} \times 64) = 122\text{mA}$ . If the current requirement of the input device is 10mA, then up to 12 input devices can be connected, DLC-02 manual, please refer <https://www.meanwell.com/Upload/PDF/DLC-02-E.pdf>

## 5. Application examples

The DLS-2XX series input devices, built with a PIR motion sensor and a daylight sensor, when combined with the MEAN WELL DLC-02 application controller and LED driver, form a DALI-2 digital lighting system. By using the DLC-02 PC software to scan the input devices and lamps on the DALI bus and configure parameters and lamp settings, users can achieve control of DALI lamps such as on/off and brightness adjustment, meeting daily lighting control needs.

Here is the relevant reference material link:

DLC-02 Manual:

<https://www.meanwell.com/Upload/PDF/DLC-02-E.pdf>

DLC-02 PC software :



<https://www.meanwell.com/Upload/PDF/DLC-02/DLC-02-SOP-E.pdf>

### 5.1 PIR Motion Sensor/Group example

Take the office pantry as an example. It is equipped with two DALI-2 lamps. When the sensor detects someone entering, it will control the lamps to turn on and set the brightness level. After the person leaves, the lamps will turn off to save energy.

#### 5.1.1 MEAN WELL DALI-2 Devices and Application Software :

- A、Two DT6-type LED drivers · model : XLC-25-H-DA2
- B、One DALI-2 controller · model : DLC-02
- C、One PIR motion sensor · model : DLS-203-P
- D、DLC-02 PC software



#### 5.1.2 Lamps grouping settings

- A. LED1~2 : Group 1

#### 5.1.3 Effect Settings

Trigger Mode	Controlled Object	Effect Description
Human movement detected	Group 1	Turn on lights at 100% brightness for 5 minutes
No human movement detected	Group 2	Turn off after 30s delay

5.1.4 The implementation steps are as follows (Steps 1 to 3 can be configured offline, and Steps 4 to 5 require connecting to DALI devices for online operation)

Step 1: Set parameters such as virtual lamp type, group, and fade time

In the "Installation" interface of the DLC-02 software, you can set the DALI parameters for lamps and input devices.

Operation Details:

- Select LED 1 under virtual lamp, set the colour type to Normal Dimming and set the fade time to 2 seconds.
- Click Bus Group Set-Edit, check Group 1 and click Save to complete the setting.
- Use the same method to set LED2's colour type to Normal Dimming and fade time to 2seconds, then add LED2 to Group 1.

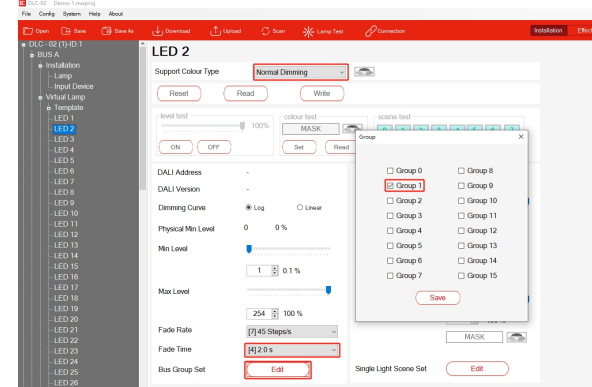
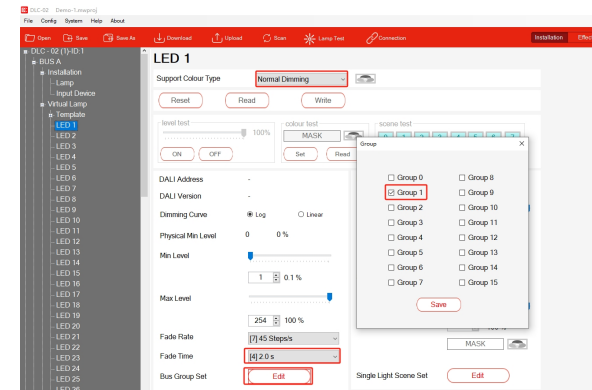

Step2: Add and configure virtual input device instances

※Add input device instances

Select "Device 1" under the Virtual Input Device, then customize its name to "DLS-203-P PIR sensor".

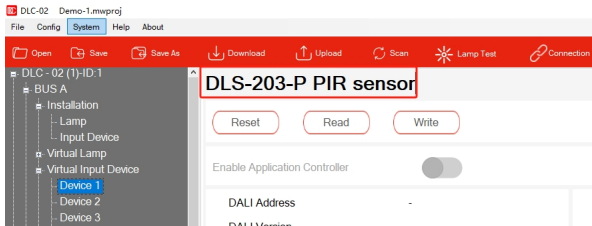

The system has a default "Button Sensor". Select it, right-click, and delete it.

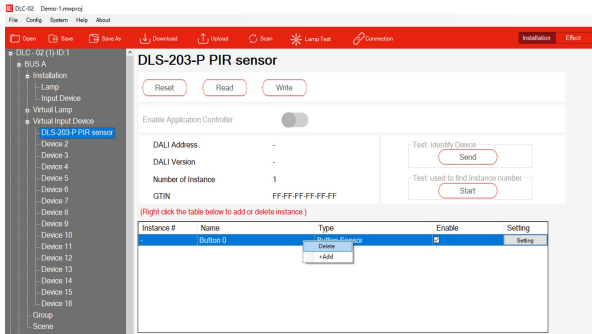

Right-click on the blank area of the instance table, select "+Add", then set the quantity of "Occupancy Sensor" to 1 and click Confirm.

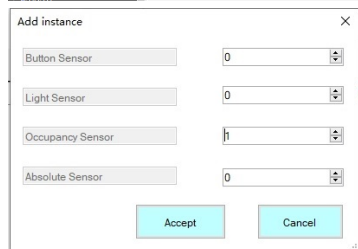
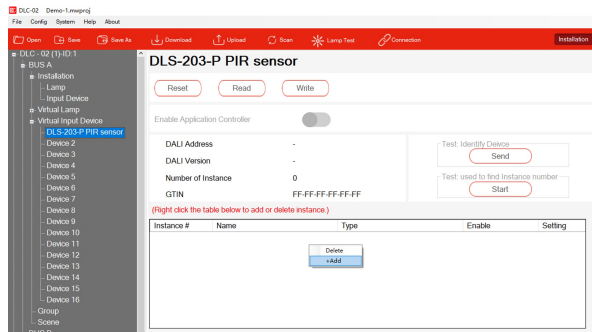

※Configure the input device instance

After adding, rename it to "Occupancy Sensor 1", check "Enable", then click the "Settings" button.

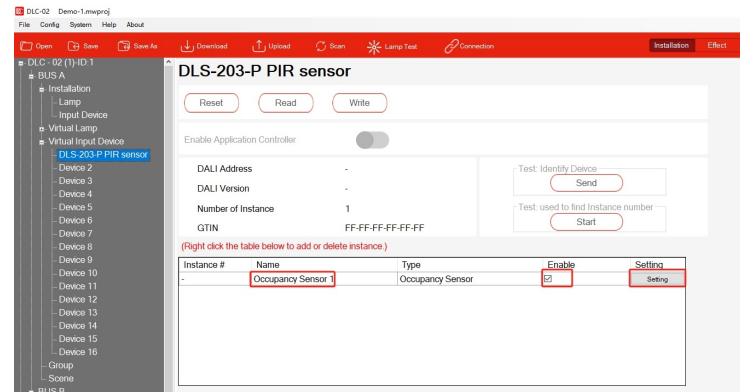

As shown in the figure below, check the Event filter related to "Occupied" and "Vacant", and set the Event Timer.

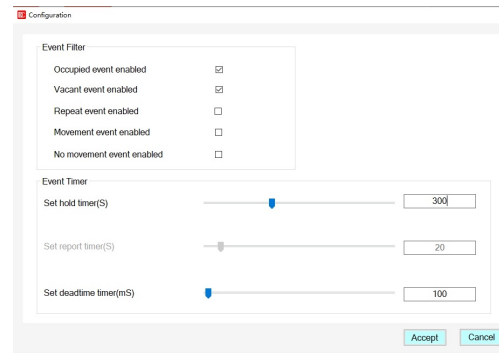

Note: For parameter descriptions of the input device, please refer to Section 4.3.3.4 of the DLC-02 Manual.

### Step 3: Effect Configuration

The control logic between input devices (PIR Sensor) and lamp groups will be configured in the "Effects" interface. Click "+Add" to create an effect.

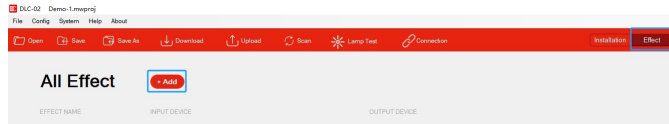

Rename "Effect 0" as "Sensor1 Controls Group1", and move "Occupancy Sensor1" in the input area and "BUS A Group1" in the output area to the right selection area.

Effect Edit

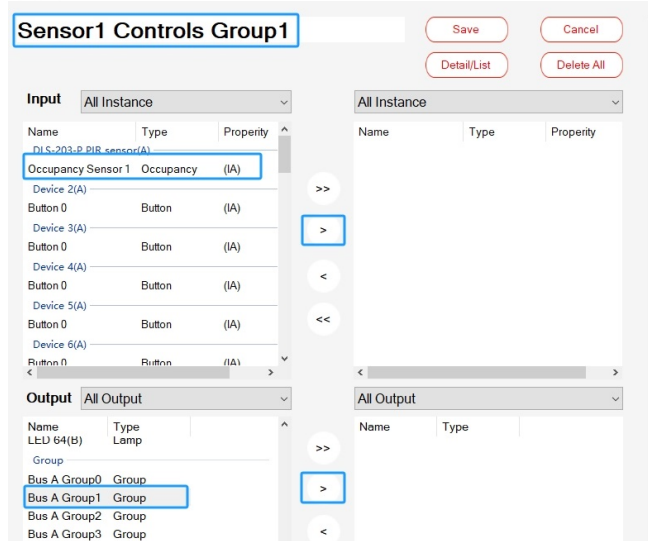

Then select "Occupancy Sensor 1", in the "Lamp/Group" section on the right, set the occupied Event Action to "Go to Level" and the brightness level to 100%; set the Vacant Event Action to "OFF" and the Delay Time to 30s. Click the Save button to complete the configuration of the control effect between "Occupancy Sensor 1" and "Bus A Group 1".

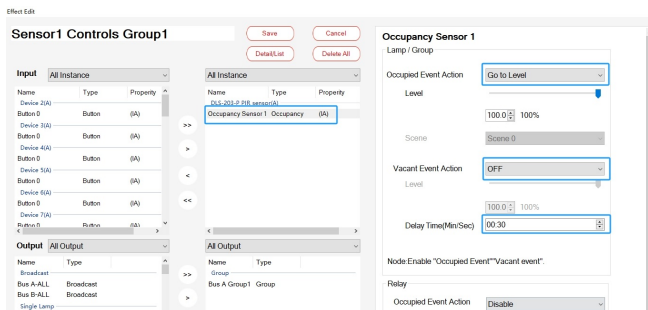

After completion, the effect list can be seen as follows.

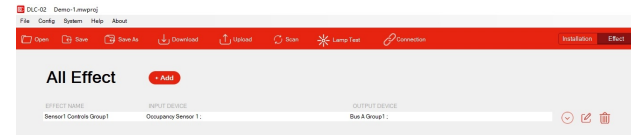

### Step 4: Pair Virtual Lamps and Input Devices with Actual Lamps and Input Devices

Connect the 2 XLC-25-H-DA2 lamps and 1 DLS-203-P input device in the pantry to the DALI-A bus of the DLC-02, then power on the AC supply. Use a USB cable to connect the computer to the USB port of the DLC-02.

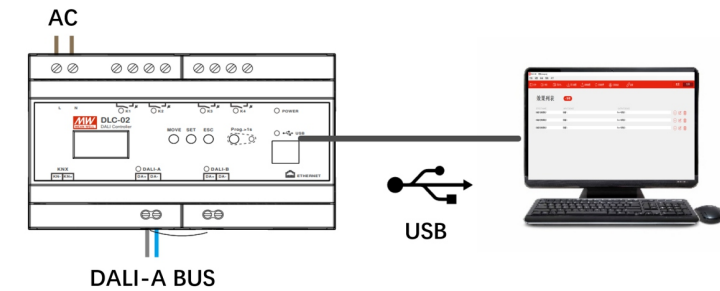

On the DLC-02 PC software, click "Connection" to establish communication between the computer and the DLC-02.

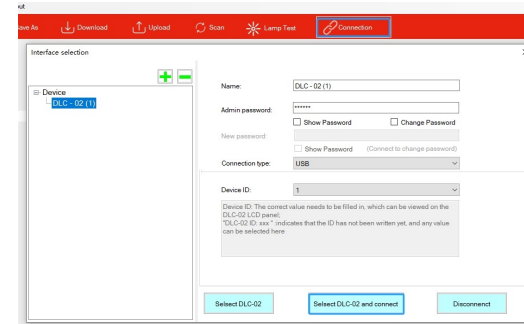

Then click "Scan - New Initialization" to scan for DALI devices online.

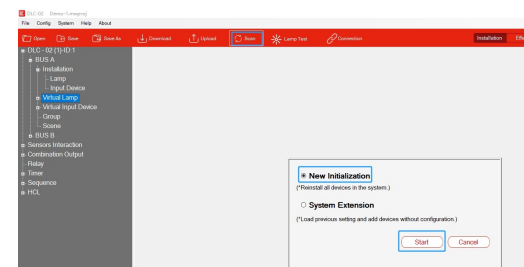

✘Pair Virtual Lamps with Actual Lamps:

After device scanning is completed, click "Bus A - Installation - Lamp". There are 2 Lamps on DALI Bus A. Select a lamp by its DALI address and click "Flash" for testing to locate the actual position of the lamp.

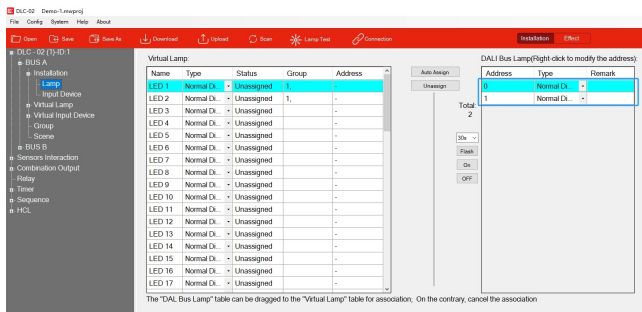

According to the actual positions of the lamps, use the mouse to select the DALI lamps on the right area, and drag them to the corresponding positions of the Virtual Lamp on the left area to complete the pairing.

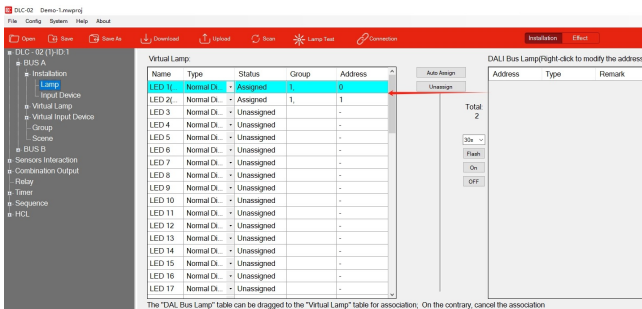

✘Pairing Virtual Input Devices with Actual Input Devices

After completing device scanning, click "Bus A - Installation - Input Device". There is 1 input device on DALI Bus A. Select the device, and 2 instances of the device will be displayed in the lower-right corner.

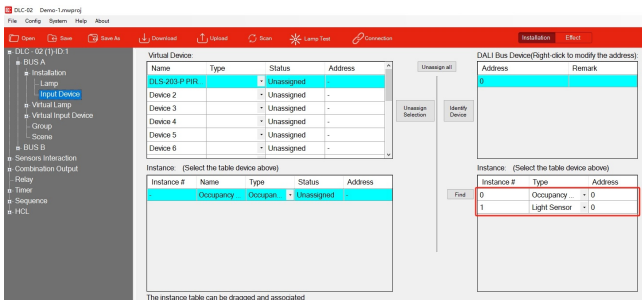

Select "Occupancy Sensor" on the right with the mouse, move it to the virtual instance position on the left, and complete the occupancy sensor pairing.

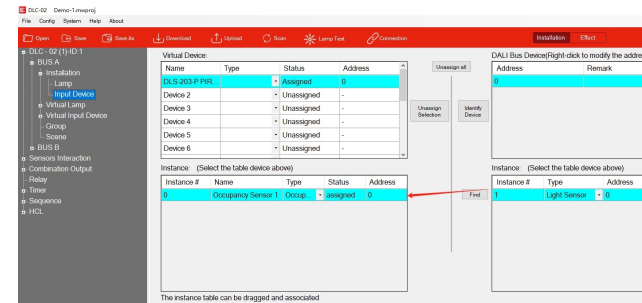

Step 5: Finally, click "Download - Device Parameter and Effects" to download all device parameters and effect configurations to the lamps, input devices, and the DLC-02 controller.

After the download is complete, the DLS-203-P can detect human movement and the current illuminance value to adjust the on/off state and brightness of the pantry lamps.

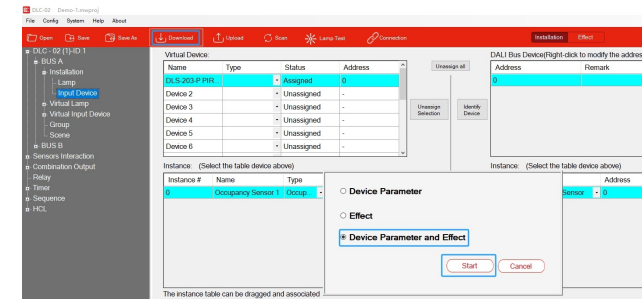

## 5.2 Light and PIR Motion Sensors Interaction/Group Example

Taking the office pantry as an example again: if the pantry is near a window, it is usually sufficiently lit during the day, so there is no need to turn on the lights. Supplementary lighting is necessary on cloudy days or at night. The pantry is equipped with two DALI-2 lamps. When the PIR motion sensor detects human presence and the light sensor detects insufficient light level, it will control the lamps to turn on and set the brightness level. The lamps will automatically turn off after the area is unoccupied to conserve energy.

### 5.2.1 MEAN WELL DALI-2 Devices and Application Software

- A · Two DT6-type LED drivers · model : XLC-25-H-DA2
- B · One DALI-2 controller · model : DLC-02
- C · One PIR motion sensor · model : DLS-203-P
- D · DLC-02 PC software



### 5.2.2 Lamps grouping settings

- A. LED1~2 : Group 1

### 5.2.3 Effect Settings

Trigger Mode	Controlled Object	Effect Description
Human movement detected, light good now.	Group1	Keep the lights off
Human movement detected, light low now	Group1	Turn on the lights at 100% brightness for 5 minutes
No human movement detected	Group1	Turn off the lights

5.2.4 The implementation steps are as follows (Steps 1 to 3 can be configured offline, and Steps 4 to 5 require connecting to DALI devices for online operation).

Step1: Set parameters such as virtual lamp type, group, and fade time.

In the "Installation" interface of the DLC-02 software, you can set the DALI parameters for lamps and input devices.

Operation Details:

- Select LED 1 under Virtual Lamp, set the colour type to Normal Dimming and set the fade time to 2 seconds.
- Click Bus Group Set-Edit, check Group 1 and click Save to complete the setting.
- Use the same method to set LED2's colour type to Normal Dimming and fade time to 2 seconds, then add LED2 to Group 1.

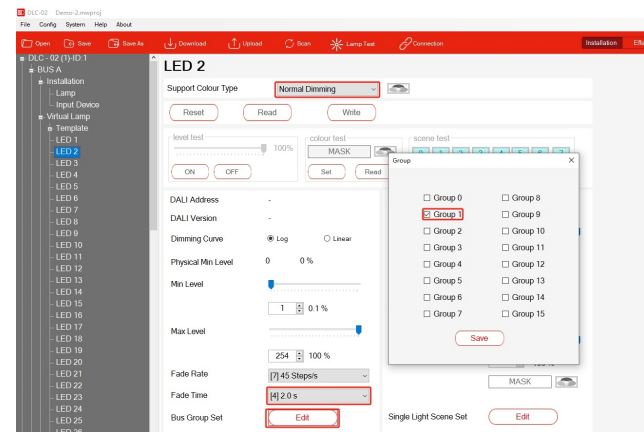
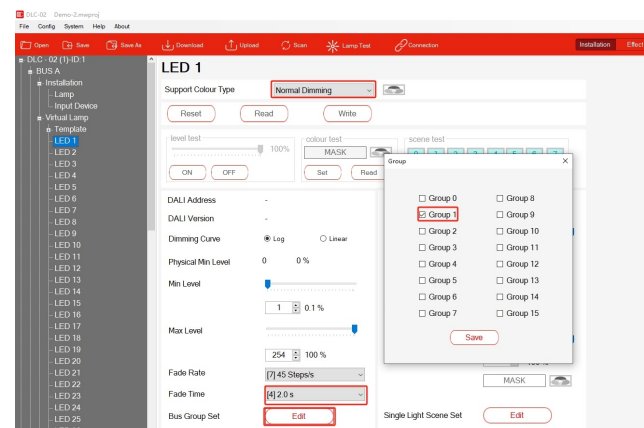

Step2:Add and configure virtual input device instances

※Add input device instances

Select "Device 1" under "Virtual Input Device". You can customize its name to "DLS-203-P PIR Sensor".

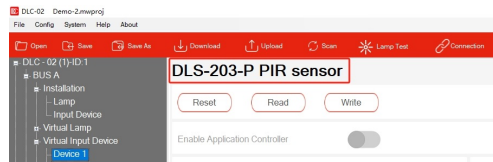

The system has a default "Button Sensor". Select it, right-click, and delete it.

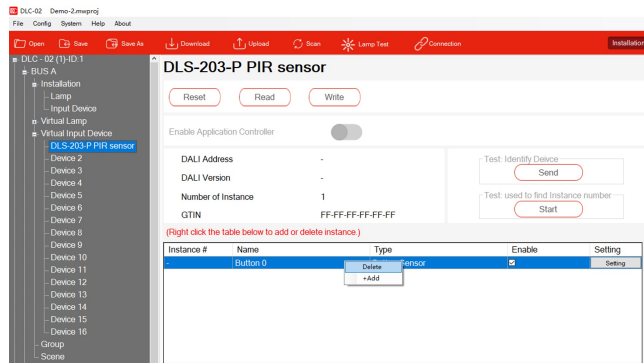

Right-click on the blank area of the instance table, select "+Add", then change the quantities of "Occupancy Sensor" and "Light Sensor" to 1, and click "Accept".

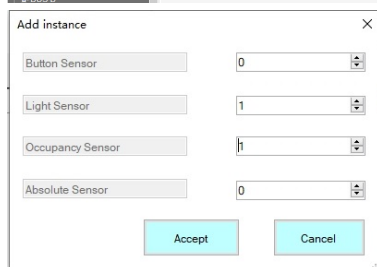
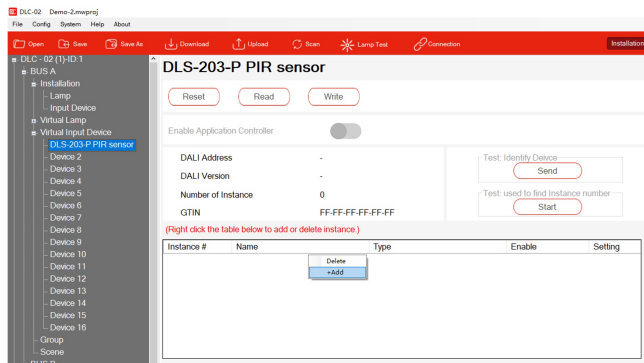

※Configure the input device instance

We can rename them to "Occupancy Sensor 1" and "Light Sensor 1", and check "Enable", then click the "Setting" button respectively.

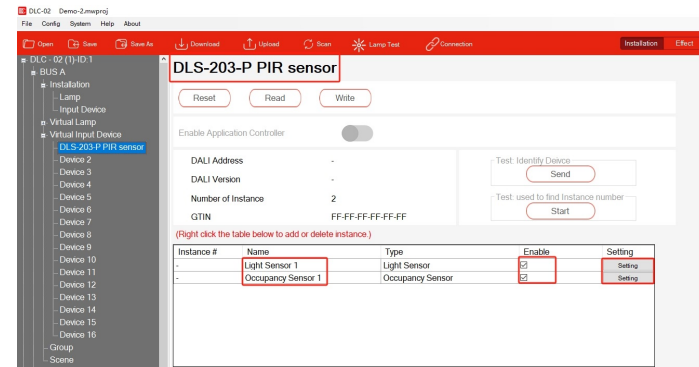

Check the Event Filter related to "Illuminance level" and set the Event Timer for "Light Sensor 1".

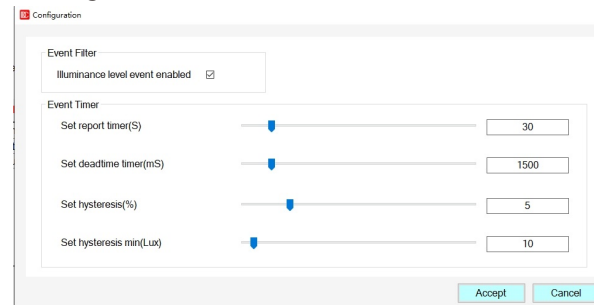

Check the Event Filter related to "Occupied" and "Vacant" and set the Event Timer for "Occupancy Sensor 1".

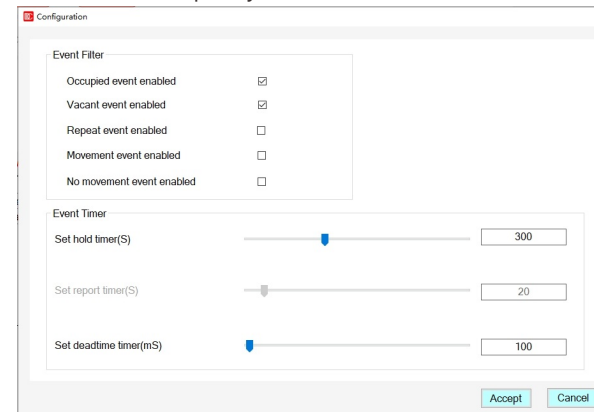

Note: For parameter descriptions of the input device, please refer to Section 4.3.3.4 of the DLC-02 Manual.

### Step 3: Add and configure Sensors Interaction

Select "Sensors Interaction" and left-click "+Add", and a "Sensors Interaction 1" will be added.

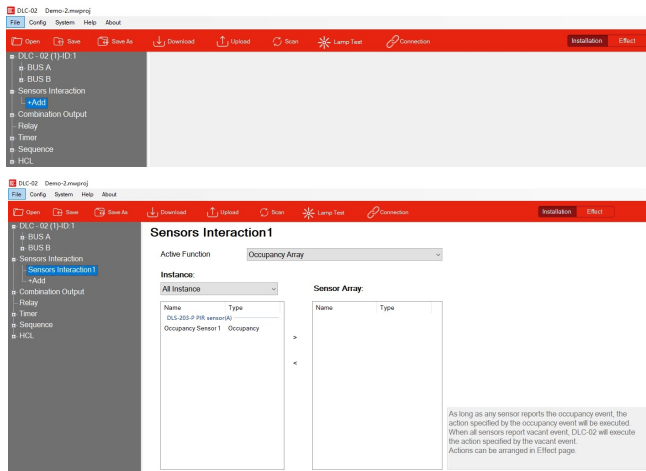

Select "Light regulation when occupied" in the "Active Function" section. Then select both "Light Sensor 1" and "Occupancy Sensor 1" simultaneously, click ">", and the "Sensors Interaction 1" will be completed.

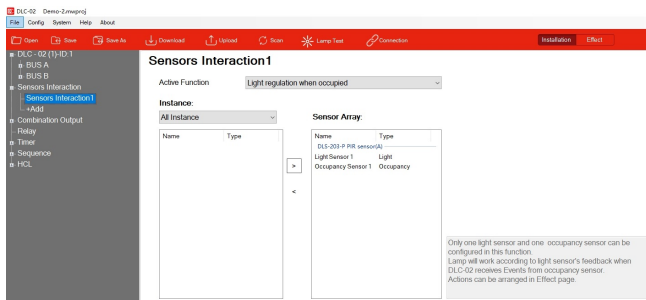
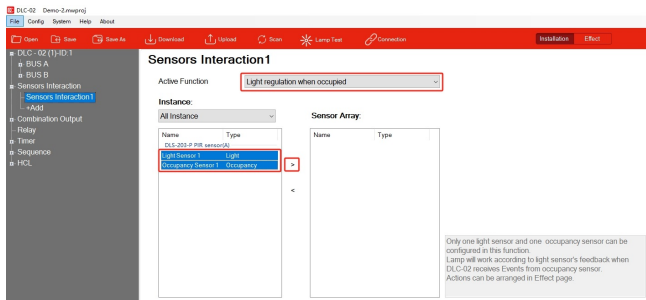

### Step 4: Effect Configuration

The control logic between input devices (PIR Sensor) and lamp groups will be configured in the "Effects" interface. Click "+Add" to create an effect: Effects.

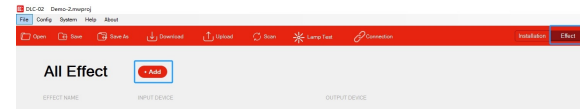

Rename the "Effect 0" as "Sensors Control Group 1", and move both "Sensors Interaction1" in the input area and "BUS A Group 1" in the output area to the right selection area.

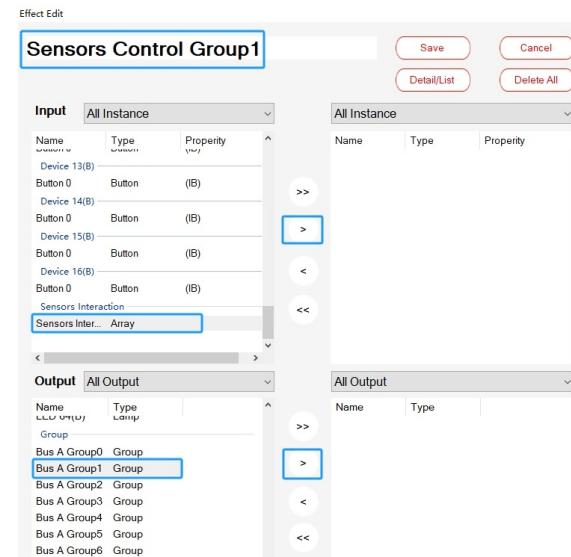

Select "Sensors Interaction 1". Below the "Sensors Interaction 1" section, click "Read" to read the Environment Light Level (when online). Set the "Reference unit" to "lx"; refer to the specification sheet to set the "Sensor Lux Range" to 2-60000 lx, and set "Set Light Sensor Level (L-H)" to 300~2000 lx. For the "Action when someone enters", select "Go to Level" and set the Level to 100%; for the "Action when person leaves", select "Off".

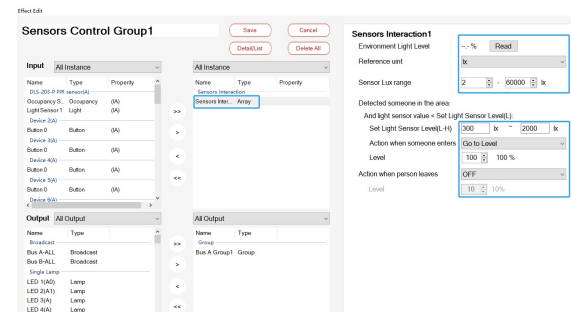

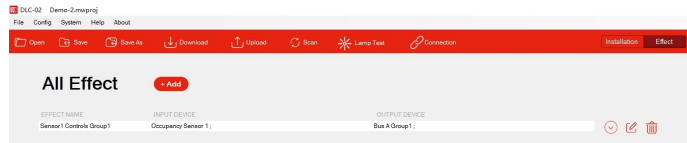

Step 5: Pair Virtual Lamps and Input Devices with Actual Lamps and Input Devices

### ✂Device Scanning

Connect the 2 XLC-25-H-DA2 lamps and 1 DLS-203-P input device in the pantry to the DALI-A bus of the DLC-02, then power on the AC supply. Use a USB cable to connect the computer to the USB port of the DLC-02.

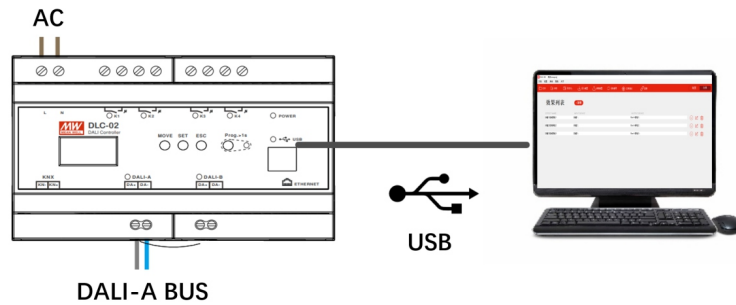

On the DLC-02 PC software, click " Connection" to establish communication between the computer and the DLC-02.

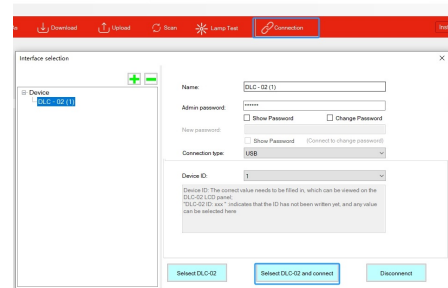

Then click " Scan - New Initialization " to scan for DALI devices online.

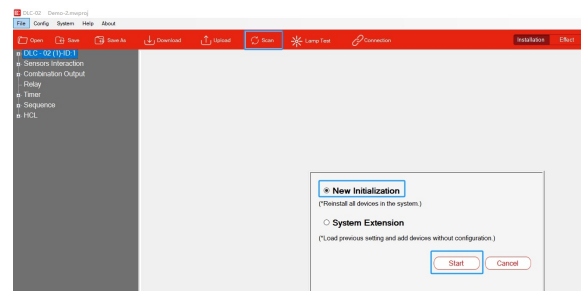

### ✂Pair Virtual Lamps with Actual Lamps

After device scanning is completed, click " Bus A - Installation - lamp ". There are 2 Lamps on DALI Bus A. Select a lamp by its DALI address and click "Flash" for testing to locate the actual position of the lamp.

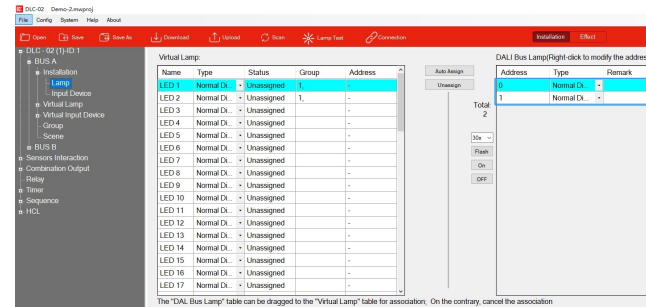

According to the actual positions of the lamps, use the mouse to select the DALI lamps on the right area, and drag them to the corresponding positions of the Virtual Lamp on the left area to complete the pairing.

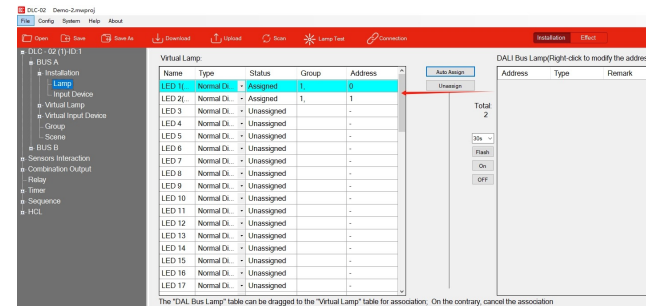

### ✂️ Pairing Virtual Input Devices with Actual Input Devices

After completing device scanning, click " Bus A - Installation - Input Device", There is 1 input device on DALI Bus A. Select the device, and 2 instances of the device will be displayed in the lower-right corner.

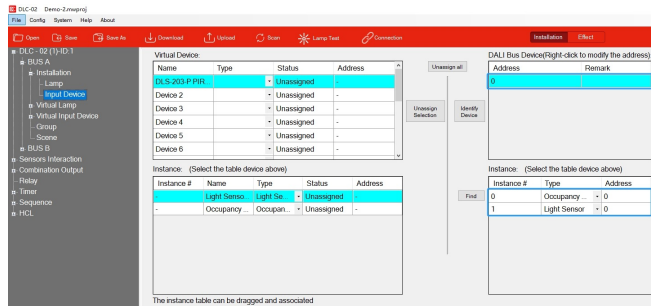

Use the mouse to select "Occupancy sensor" and "Light sensor" in the "Instance" section at the bottom right, then move them respectively to the corresponding positions of the virtual device instances on the left to complete the pairing.

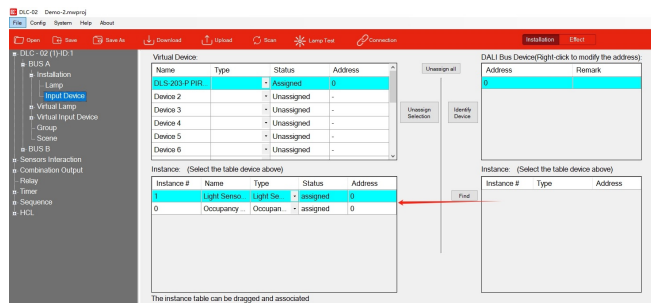

### Step 6: Download-Device Parameter and Effect

Finally, click " Download-Device Parameter and Effect " to download all device parameters and effect configurations to the lamps, input devices, and the DLC-02 controller.

After the download is complete, the DLS-203-P can detect human movement and the current illuminance value to adjust the on/off state and brightness of the pantry lamps.

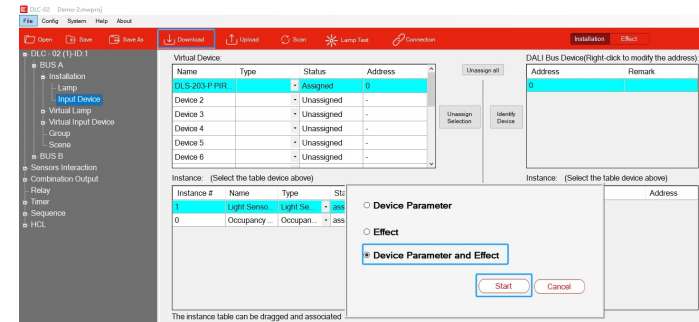

## 6.Common Faults and Troubleshooting

Fault Type	Specific Symptom	Troubleshooting Steps	Solution
Power Supply/ Communication Abnormality	No indicator lights on at all, unable to communicate with the DALI driver	1. Check if the DALI bus power supply voltage is within the range of 9.5 - 22.5V DC 2. Inspect if the terminal wiring is loose or disconnected 3. Confirm whether the total bus line length exceeds 300m and the total number of sensors exceeds 16	1. Repair the bus power supply to ensure the voltage is stable and meets the standards 2. Reconnect the wiring terminals firmly 3. Shorten the bus line and reduce the number of sensors to the rated range
No sensing	There are obvious movements such as people walking within the detection range, but the detector has no trigger signal and the working light does not turn on	1. Check if the PIR probe is covered with dust, oil stains, or blocked by ceiling decorations and lamps 2. Confirm if the installation height is within the recommended range	1. Gently wipe the probe with alcohol and remove the obstructions 2. Adjust the installation height to the optimal value (3 meters for DLS-203-P; 8 meters for DLS-208-P) and align it with the target activity area
Frequent False Triggers	Frequent triggers occur when there is no human activity, causing the driven lamps to turn on and off repeatedly	1. Check if the daylight sensor is directly facing strong light or reflective surfaces 2. Check if the PIR probe is close to heat sources such as air conditioning vents and heating equipment 3. Confirm if the duration setting is too short (e.g., 5s, which is prone to causing false trigger chain reactions)	1. Adjust the installation position to avoid direct strong light and reflective scenarios 2. Keep away from heat sources and prevent air flow from blowing directly on the probe 3. Adjust the duration to 30s or more
Sensor detection range attenuation	Triggers only at close range, with no response to activities in the edge area or from the side	1. Check if the Fresnel lens is damaged or aged 2. Confirm if the ambient temperature deviates from 25°C (the detection performance is optimal at this temperature)	1. Replace the Fresnel lens with the same model and avoid scratching the lens surface 2. If the ambient temperature is too high or too low, temperature control measures can be used to improve the situation

## 7.Warranty

This product provides five years warranty under normal usage. Do not replace parts or any form of modification to the product in order to keep the warranty effectively.

✘MEAN WELL possesses the right to adjust the content of this manual.  
Please refer to the latest version of our manual on our website.  
<https://www.meanwell.com>

## 8.Environmental declaration information

[https://www.meanwell.com//Upload/PDF/RoHS\\_PFOS.pdf](https://www.meanwell.com//Upload/PDF/RoHS_PFOS.pdf)  
[https://www.meanwell.com//Upload/PDF/REACH\\_SVHC.pdf](https://www.meanwell.com//Upload/PDF/REACH_SVHC.pdf)  
[https://www.meanwell.com//Upload/PDF/Declaration\\_RoHS-E.pdf](https://www.meanwell.com//Upload/PDF/Declaration_RoHS-E.pdf)

**明緯企業股份有限公司**  
**MEAN WELL ENTERPRISES CO., LTD.**

248 新北市五股區五權三路28號  
No.28, Wuquan 3rd Rd., Wugu Dist., New Taipei City 248, Taiwan  
Tel:886-2-2299-6100 Fax:886-2-2299-6200  
<http://www.meanwell.com> E-mail:[info@meanwell.com](mailto:info@meanwell.com)